

## **CAUTION**

All Zipp Crank and BB products should be installed by a professional bicycle mechanic using the appropriate tools.

Zipp assumes no responsibility for damages or injury related to improperly installed components.

## **CRITICAL DETAILS**

1. The Zipp 300 crankset is designed only for use with ISIS compatible and approved Bottom Brackets. The Zipp 300 is designed to have 43.5mm chainline when used with Isis 108mm BB spindle.
2. Zipp model 300 crank has 130mm bolt circle for use with 130mm BCD chainrings only. The Zipp chainrings are designed for optimal performance with both 9 and 10 speed systems.
3. The Zipp 300 comes with chainrings installed using Zipp double-hex key bolts/nuts and is pre-torqued to the proper torque of 8 N.m
4. The Zipp 300 utilizes self extracting bolts, there is no need to use a crank extractor to remove the crankset, simply unscrew the crank attachment against the silver extractor cap until the crank arm comes free from the BB spindle.
5. The Zipp 300 is designed to function optimally with Zipp 180 BB as an integrated system. The ISIS standards are set so that any crank should work with any BB; however, Zipp makes no claims to the dimensional accuracy or tolerance control of non-Zipp components and therefore cannot be responsible for damage or injury resulting from mixing Zipp and non-Zipp components.

## **Overview and components**

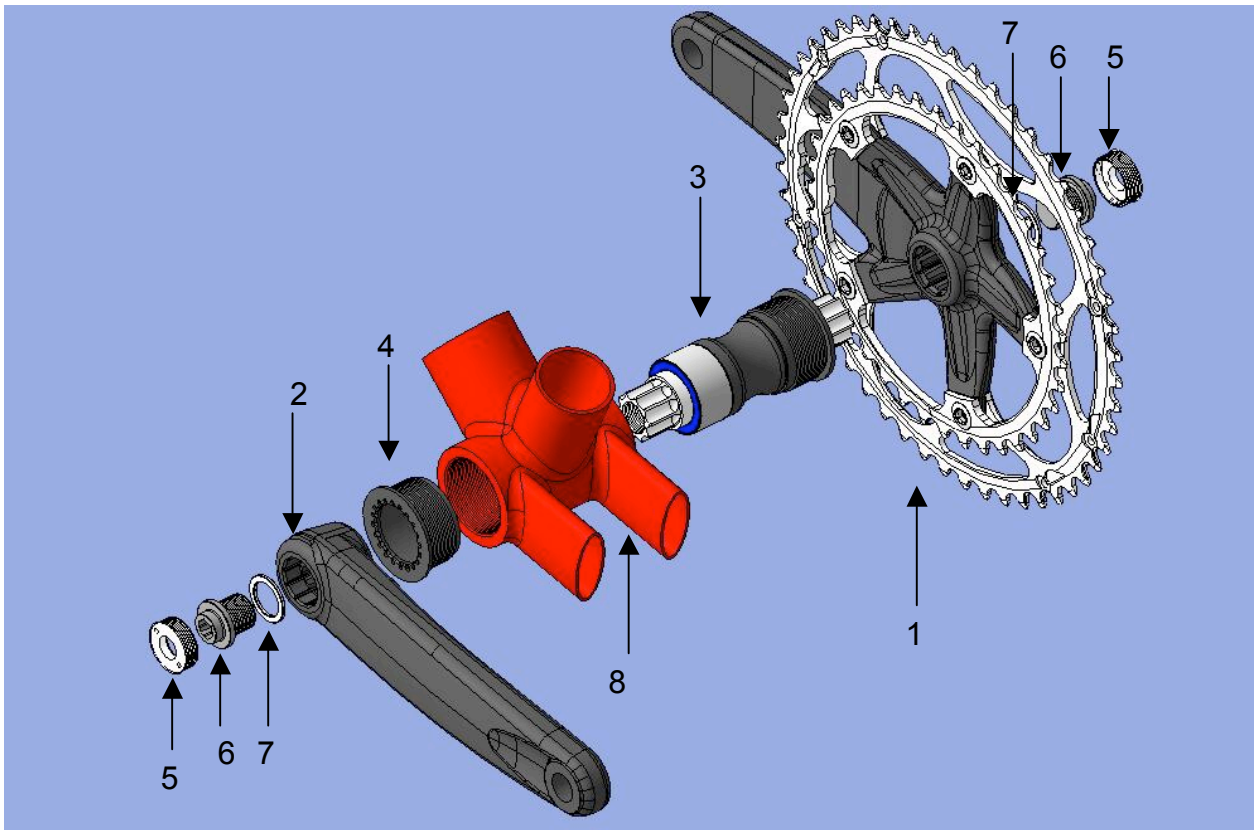

1. Right Crank arm with chainrings
2. Left Crank Arm
3. Bottom Bracket with Drive side cup
4. Bottom Bracket non-drive cup
5. 7076-T651 Extractor Cap
6. 6Al/4V Titanium Bolt
7. Hardened Steel Washer
8. BB Shell

#### **INSTALLATION:**

1. Check to insure that the BB you have matches the thread of your BB shell. The BB shell should have clean threads and be properly faced on the drive side to remove any paint or burrs. Apply grease or anti-seize to the cups of the BB.
2. Thread drive side of BB into frame, using Park BBT-2 BB installation tool or similar 20 tooth BB tool for ISIS Bottom Brackets. Torque cup to 40-45N.m (354-398 in.lbs)
3. Thread non-drive cup into frame and torque to same spec. as drive side cup. This cup will bottom out on the BB assembly and properly preload the bearings at the specified torque.
4. Liberally apply grease to BB spindle and threads before installing crank arm. The spindle **MUST** be greased to allow the crank to be properly pre-loaded at the require torque.

5. Your Zipp crank arms are supplied with crank bolts and extractors in place. If you have removed the extractor cap or bolt for any reason, you must ensure that the hardened steel washer is replaced under the bolt during reassembly. Failure to use the hardened steel washer will damage the crankset and void the warranty.
6. Align right crankarm with ISIS spline by pushing arm against spindle and rotating to feel when crank is properly indexed. Begin to thread arm onto spindle loosely making sure of proper alignment, failure to align crank arm and bottom bracket spindle can damage crankset, this installation error will not be covered under warranty.
7. Use 8mm Hex key to tighten crank onto spindle. The crank arm will bottom out on the shoulder/stop on spindle before design torque is achieved. Use a torque wrench to tighten crank bolt to 40 N.m. (354 in.lbs).
8. Align left crank arm opposite to right crank arm onto BB spindle, repeating methods described in 6 and 7.
9. Check crank bolts after the first 50-100 km of use to ensure they have not loosened. Afterwards, check bolt torque every 6 months to ensure proper torque is maintained.

### **Crank Removal**

Your Zipp 300 crank utilizes self extracting bolts which have an aluminum cap threaded into the 22x1mm thread commonly used to remove cranks. To remove cranks using the extractor simply screw crank bolt counterclockwise leaving the aluminum extractor cap in place. The bolt will loosen easily and then be more difficult to loosen as it pulls the crankarm from the taper, and then become easy again, this is normal, just keep unscrewing until the crank arm is removed from the BB.

If you choose to remove or not to use the Zipp self-extracting bolt, you will need an extraction tool such as the Park CCP-4 for ISIS spindles. This tool must be threaded into the 22x1mm thread in the crank arm to full depth before beginning removal; failure to do so may result in damage and will not be covered under warranty.

### **Chainring Installation**

Your Zipp crankset comes with Zipp proprietary design 7075-T651 chainrings already installed. If you must remove them or wish to replace them you must be careful to properly align the chainrings before installation. The chainrings should be located with the printing facing away from the bicycle and the alignment indicators (shown) should be aligned with the crank arm.

Zipp chainring bolts and nuts use hex keys on both bolt and nut, and therefore require no special tools. A 6mm hex key and 5mm hex key are all that is required to properly torque the chainring bolts. Assemble all 5 bolts finger tight, and then tighten to torque specification of 9-10 N.m (80-88 in.lbs)

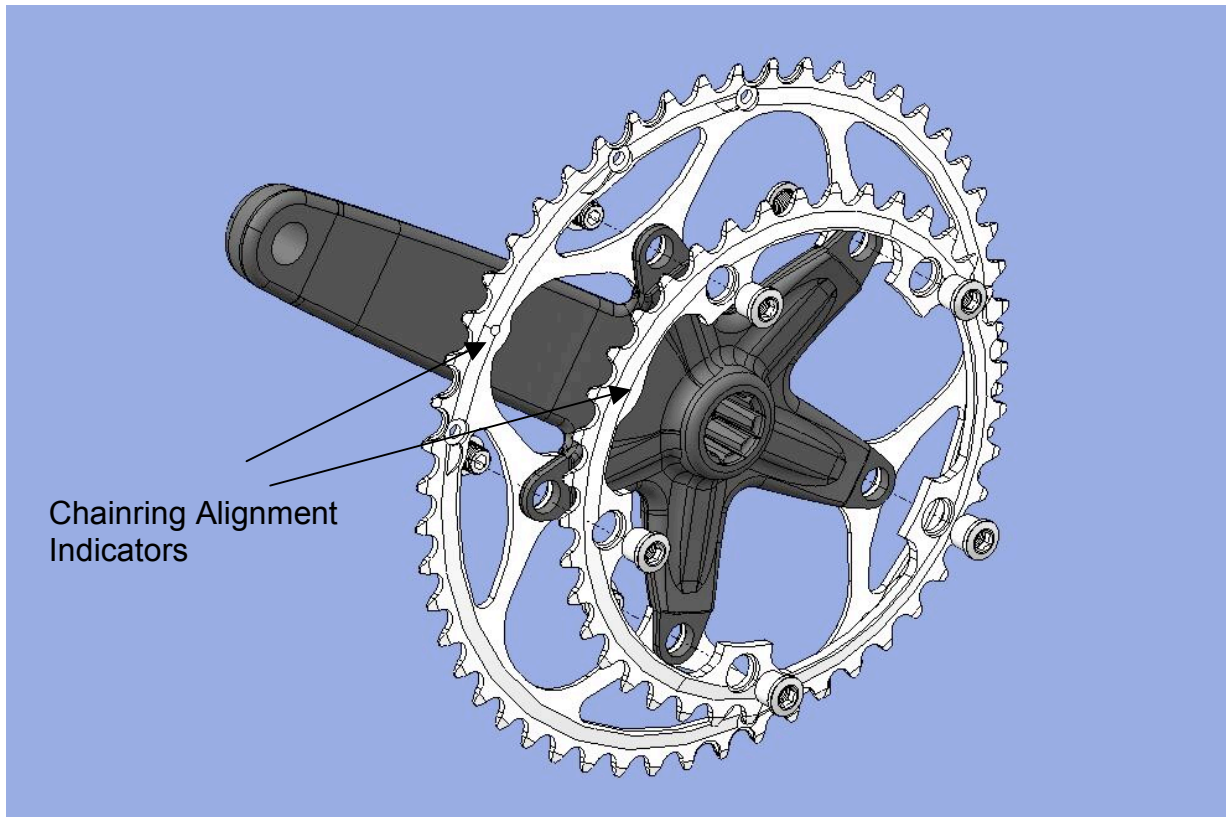

Bolt torque inspections should be done a minimum of 2 times per year. During this time, also inspect all parts for damage, visible cracks or chips. All components should be inspected thoroughly after any crash or accident, if any damage, cracks, chips, stress marks, or discoloration is visible, these products must be replaced immediately and not used any further. Failure to do so may result in serious injury.

**Warranty:**

This product is guaranteed for 1 year against defects in materials and workmanship. Warranty is for original owner only and proof of purchase is required for any warranty claim. Product modification of any kind, including but not limited to drilling, filing, grinding, painting, any attempt to remove weight or change compatibility will immediately void warranty.

Any questions please visit [www.zipp.com](http://www.zipp.com) or call us at 1.800.472.3972